

Notice of Intent

For

4 Nipmuc Drive

Mendon, MA.

Date:

March 19, 2021

Prepared for:

Jason LLC

P.O. Box 444

Mendon, MA. 01756



**Guerriere &
Halnon, Inc.**
ENGINEERING & LAND SURVEYING



Massachusetts Department of Environmental Protection
Bureau of Resource Protection - Wetlands
WPA Form 3 – Notice of Intent
 Massachusetts Wetlands Protection Act M.G.L. c. 131, §40

Provided by MassDEP:

MassDEP File Number
Document Transaction Number
City/Town

Important:
 When filling out forms on the computer, use only the tab key to move your cursor - do not use the return key.

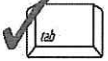

Note:
 Before completing this form consult your local Conservation Commission regarding any municipal bylaw or ordinance.

A. General Information

1. Project Location (**Note:** electronic filers will click on button to locate project site):

<u>4 Nipmuc Drive</u>	<u>Mendon</u>	<u>01756</u>
a. Street Address	b. City/Town	c. Zip Code
Latitude and Longitude:		
<u>10</u>	<u>236-106</u>	<u></u>
f. Assessors Map/Plat Number	d. Latitude	e. Longitude
	g. Parcel /Lot Number	

2. Applicant:

<u>Barbara</u>	<u>Leland</u>	
a. First Name	b. Last Name	
<u>Jason LLC</u>		
c. Organization		
<u>P.O. Box 444</u>		
d. Street Address		
<u>Mendon</u>	<u>MA.</u>	<u>01756</u>
e. City/Town	f. State	g. Zip Code
<u>508-962-4452</u>	<u>barnam@verizon.net</u>	
h. Phone Number	i. Fax Number	j. Email Address

3. Property owner (required if different from applicant): Check if more than one owner

<u></u>	<u></u>	
a. First Name	b. Last Name	
<u></u>		
c. Organization		
<u></u>		
d. Street Address		
<u></u>	<u></u>	<u></u>
e. City/Town	f. State	g. Zip Code
<u></u>	<u></u>	<u></u>
h. Phone Number	i. Fax Number	j. Email address

4. Representative (if any):

<u>Amanda</u>	<u>Cavaliere</u>	
a. First Name	b. Last Name	
<u>Guerriere & Halnon, Inc.</u>		
c. Company		
<u>55 West Central St.</u>		
d. Street Address		
<u>Franklin</u>	<u>MA.</u>	<u>02038</u>
e. City/Town	f. State	g. Zip Code
<u>508-528-3221</u>	<u>acavaliere@gandhengineering.com</u>	
h. Phone Number	i. Fax Number	j. Email address

5. Total WPA Fee Paid (from NOI Wetland Fee Transmittal Form):

<u>110.00</u>	<u>42.50</u>	<u>67.50</u>
a. Total Fee Paid	b. State Fee Paid	c. City/Town Fee Paid



Massachusetts Department of Environmental Protection
 Bureau of Resource Protection - Wetlands
WPA Form 3 – Notice of Intent
 Massachusetts Wetlands Protection Act M.G.L. c. 131, §40

Provided by MassDEP:

MassDEP File Number

Document Transaction Number

City/Town

A. General Information (continued)

6. General Project Description:

Proposed carport addition with an addition of steps and a dock on an existing lot to have access to the water.

7a. Project Type Checklist: (Limited Project Types see Section A. 7b.)

- 1. Single Family Home
- 2. Residential Subdivision
- 3. Commercial/Industrial
- 4. Dock/Pier
- 5. Utilities
- 6. Coastal engineering Structure
- 7. Agriculture (e.g., cranberries, forestry)
- 8. Transportation
- 9. Other

7b. Is any portion of the proposed activity eligible to be treated as a limited project (including Ecological Restoration Limited Project) subject to 310 CMR 10.24 (coastal) or 310 CMR 10.53 (inland)?

1. Yes No If yes, describe which limited project applies to this project. (See 310 CMR 10.24 and 10.53 for a complete list and description of limited project types)

2. Limited Project Type

If the proposed activity is eligible to be treated as an Ecological Restoration Limited Project (310 CMR10.24(8), 310 CMR 10.53(4)), complete and attach Appendix A: Ecological Restoration Limited Project Checklist and Signed Certification.

8. Property recorded at the Registry of Deeds for:

Worcester County

a. County

941

c. Book

b. Certificate # (if registered land)

Plan 118 April 2019

d. Page Number

B. Buffer Zone & Resource Area Impacts (temporary & permanent)

- 1. Buffer Zone Only – Check if the project is located only in the Buffer Zone of a Bordering Vegetated Wetland, Inland Bank, or Coastal Resource Area.
- 2. Inland Resource Areas (see 310 CMR 10.54-10.58; if not applicable, go to Section B.3, Coastal Resource Areas).

Check all that apply below. Attach narrative and any supporting documentation describing how the project will meet all performance standards for each of the resource areas altered, including standards requiring consideration of alternative project design or location.



Massachusetts Department of Environmental Protection
 Bureau of Resource Protection - Wetlands
WPA Form 3 – Notice of Intent
 Massachusetts Wetlands Protection Act M.G.L. c. 131, §40

Provided by MassDEP:

MassDEP File Number
Document Transaction Number
City/Town

B. Buffer Zone & Resource Area Impacts (temporary & permanent) (cont'd)

For all projects affecting other Resource Areas, please attach a narrative explaining how the resource area was delineated.

Resource Area	Size of Proposed Alteration	Proposed Replacement (if any)
a. <input type="checkbox"/> Bank	1. linear feet _____	2. linear feet _____
b. <input checked="" type="checkbox"/> Bordering Vegetated Wetland	1. square feet _____	2. square feet _____
c. <input type="checkbox"/> Land Under Waterbodies and Waterways	1. square feet _____	2. square feet _____
	3. cubic yards dredged _____	

Resource Area	Size of Proposed Alteration	Proposed Replacement (if any)
d. <input type="checkbox"/> Bordering Land Subject to Flooding	1. square feet _____	2. square feet _____
	3. cubic feet of flood storage lost _____	4. cubic feet replaced _____
e. <input type="checkbox"/> Isolated Land Subject to Flooding	1. square feet _____	
	2. cubic feet of flood storage lost _____	3. cubic feet replaced _____

- f. Riverfront Area
- Name of Waterway (if available) - **specify coastal or inland** _____
 - Width of Riverfront Area (check one):
 - 25 ft. - Designated Densely Developed Areas only
 - 100 ft. - New agricultural projects only
 - 200 ft. - All other projects

3. Total area of Riverfront Area on the site of the proposed project: _____ square feet

4. Proposed alteration of the Riverfront Area:

a. total square feet _____	b. square feet within 100 ft. _____	c. square feet between 100 ft. and 200 ft. _____
----------------------------	-------------------------------------	--

5. Has an alternatives analysis been done and is it attached to this NOI? Yes No

6. Was the lot where the activity is proposed created prior to August 1, 1996? Yes No

3. Coastal Resource Areas: (See 310 CMR 10.25-10.35)

Note: for coastal riverfront areas, please complete **Section B.2.f.** above.



Massachusetts Department of Environmental Protection
 Bureau of Resource Protection - Wetlands
WPA Form 3 – Notice of Intent
 Massachusetts Wetlands Protection Act M.G.L. c. 131, §40

Provided by MassDEP:

MassDEP File Number
Document Transaction Number
City/Town

B. Buffer Zone & Resource Area Impacts (temporary & permanent) (cont'd)

Check all that apply below. Attach narrative and supporting documentation describing how the project will meet all performance standards for each of the resource areas altered, including standards requiring consideration of alternative project design or location.

Online Users:
 Include your document transaction number (provided on your receipt page) with all supplementary information you submit to the Department.

Resource Area	Size of Proposed Alteration	Proposed Replacement (if any)
a. <input type="checkbox"/> Designated Port Areas	Indicate size under Land Under the Ocean, below	
b. <input type="checkbox"/> Land Under the Ocean	1. square feet _____	
	2. cubic yards dredged _____	
c. <input type="checkbox"/> Barrier Beach	Indicate size under Coastal Beaches and/or Coastal Dunes below	
d. <input type="checkbox"/> Coastal Beaches	1. square feet _____	2. cubic yards beach nourishment _____
e. <input type="checkbox"/> Coastal Dunes	1. square feet _____	2. cubic yards dune nourishment _____
	Size of Proposed Alteration	Proposed Replacement (if any)
f. <input type="checkbox"/> Coastal Banks	1. linear feet _____	
g. <input type="checkbox"/> Rocky Intertidal Shores	1. square feet _____	
h. <input type="checkbox"/> Salt Marshes	1. square feet _____	2. sq ft restoration, rehab., creation _____
i. <input type="checkbox"/> Land Under Salt Ponds	1. square feet _____	
	2. cubic yards dredged _____	
j. <input type="checkbox"/> Land Containing Shellfish	1. square feet _____	
k. <input type="checkbox"/> Fish Runs	Indicate size under Coastal Banks, inland Bank, Land Under the Ocean, and/or inland Land Under Waterbodies and Waterways, above	
	1. cubic yards dredged _____	
l. <input type="checkbox"/> Land Subject to Coastal Storm Flowage	1. square feet _____	

4. Restoration/Enhancement

If the project is for the purpose of restoring or enhancing a wetland resource area in addition to the square footage that has been entered in Section B.2.b or B.3.h above, please enter the additional amount here.

_____ a. square feet of BVW	_____ b. square feet of Salt Marsh
-----------------------------	------------------------------------

5. Project Involves Stream Crossings

_____ a. number of new stream crossings	_____ b. number of replacement stream crossings
---	---



Massachusetts Department of Environmental Protection
Bureau of Resource Protection - Wetlands

WPA Form 3 – Notice of Intent

Massachusetts Wetlands Protection Act M.G.L. c. 131, §40

Provided by MassDEP:

MassDEP File Number

Document Transaction Number

City/Town

C. Other Applicable Standards and Requirements

- This is a proposal for an Ecological Restoration Limited Project. Skip Section C and complete Appendix A: Ecological Restoration Limited Project Checklists – Required Actions (310 CMR 10.11).

Streamlined Massachusetts Endangered Species Act/Wetlands Protection Act Review

1. Is any portion of the proposed project located in **Estimated Habitat of Rare Wildlife** as indicated on the most recent Estimated Habitat Map of State-Listed Rare Wetland Wildlife published by the Natural Heritage and Endangered Species Program (NHESP)? To view habitat maps, see the *Massachusetts Natural Heritage Atlas* or go to http://maps.massgis.state.ma.us/PRI_EST_HAB/viewer.htm.

a. Yes No

If yes, include proof of mailing or hand delivery of NOI to:

Natural Heritage and Endangered Species Program
Division of Fisheries and Wildlife
1 Rabbit Hill Road
Westborough, MA 01581

on-line _____

b. Date of map _____

If yes, the project is also subject to Massachusetts Endangered Species Act (MESA) review (321 CMR 10.18). To qualify for a streamlined, 30-day, MESA/Wetlands Protection Act review, please complete Section C.1.c, and include requested materials with this Notice of Intent (NOI); *OR* complete Section C.2.f, if applicable. *If MESA supplemental information is not included with the NOI, by completing Section 1 of this form, the NHESP will require a separate MESA filing which may take up to 90 days to review (unless noted exceptions in Section 2 apply, see below).*

- c. Submit Supplemental Information for Endangered Species Review*

1. Percentage/acreage of property to be altered:

(a) within wetland Resource Area

_____ percentage/acreage

(b) outside Resource Area

_____ percentage/acreage

2. Assessor's Map or right-of-way plan of site

2. Project plans for entire project site, including wetland resource areas and areas outside of wetlands jurisdiction, showing existing and proposed conditions, existing and proposed tree/vegetation clearing line, and clearly demarcated limits of work **

(a) Project description (including description of impacts outside of wetland resource area & buffer zone)

(b) Photographs representative of the site

* Some projects **not** in Estimated Habitat may be located in Priority Habitat, and require NHESP review (see <https://www.mass.gov/mass-endangered-species-act-mesa-regulatory-review>).

Priority Habitat includes habitat for state-listed plants and strictly upland species not protected by the Wetlands Protection Act.

** MESA projects may not be segmented (321 CMR 10.16). The applicant must disclose full development plans even if such plans are not required as part of the Notice of Intent process.



Massachusetts Department of Environmental Protection
Bureau of Resource Protection - Wetlands
WPA Form 3 – Notice of Intent
Massachusetts Wetlands Protection Act M.G.L. c. 131, §40

Provided by MassDEP:

MassDEP File Number

Document Transaction Number

City/Town

C. Other Applicable Standards and Requirements (cont'd)

- (c) MESA filing fee (fee information available at <https://www.mass.gov/how-to/how-to-file-for-a-mesa-project-review>).
Make check payable to "Commonwealth of Massachusetts - NHESP" and **mail to NHESP** at above address

Projects altering 10 or more acres of land, also submit:

- (d) Vegetation cover type map of site
- (e) Project plans showing Priority & Estimated Habitat boundaries
- (f) OR Check One of the Following
1. Project is exempt from MESA review.
Attach applicant letter indicating which MESA exemption applies. (See 321 CMR 10.14, <https://www.mass.gov/service-details/exemptions-from-review-for-projectsactivities-in-priority-habitat>; the NOI must still be sent to NHESP if the project is within estimated habitat pursuant to 310 CMR 10.37 and 10.59.)
 2. Separate MESA review ongoing. a. NHESP Tracking # _____ b. Date submitted to NHESP _____
 3. Separate MESA review completed.
Include copy of NHESP "no Take" determination or valid Conservation & Management Permit with approved plan.
3. For coastal projects only, is any portion of the proposed project located below the mean high water line or in a fish run?
- a. Not applicable – project is in inland resource area only b. Yes No

If yes, include proof of mailing, hand delivery, or electronic delivery of NOI to either:

South Shore - Cohasset to Rhode Island border, and the Cape & Islands:

North Shore - Hull to New Hampshire border:

Division of Marine Fisheries -
Southeast Marine Fisheries Station
Attn: Environmental Reviewer
836 South Rodney French Blvd.
New Bedford, MA 02744
Email: dmf.envreview-south@mass.gov

Division of Marine Fisheries -
North Shore Office
Attn: Environmental Reviewer
30 Emerson Avenue
Gloucester, MA 01930
Email: dmf.envreview-north@mass.gov

Also if yes, the project may require a Chapter 91 license. For coastal towns in the Northeast Region, please contact MassDEP's Boston Office. For coastal towns in the Southeast Region, please contact MassDEP's Southeast Regional Office.

- c. Is this an aquaculture project? d. Yes No

If yes, include a copy of the Division of Marine Fisheries Certification Letter (M.G.L. c. 130, § 57).



Massachusetts Department of Environmental Protection
 Bureau of Resource Protection - Wetlands
WPA Form 3 – Notice of Intent
 Massachusetts Wetlands Protection Act M.G.L. c. 131, §40

Provided by MassDEP:

MassDEP File Number

Document Transaction Number

City/Town

Online Users:
 Include your document transaction number (provided on your receipt page) with all supplementary information you submit to the Department.

C. Other Applicable Standards and Requirements (cont'd)

4. Is any portion of the proposed project within an Area of Critical Environmental Concern (ACEC)?
 a. Yes No If yes, provide name of ACEC (see instructions to WPA Form 3 or MassDEP Website for ACEC locations). **Note:** electronic filers click on Website.
- b. ACEC _____
5. Is any portion of the proposed project within an area designated as an Outstanding Resource Water (ORW) as designated in the Massachusetts Surface Water Quality Standards, 314 CMR 4.00?
 a. Yes No
6. Is any portion of the site subject to a Wetlands Restriction Order under the Inland Wetlands Restriction Act (M.G.L. c. 131, § 40A) or the Coastal Wetlands Restriction Act (M.G.L. c. 130, § 105)?
 a. Yes No
7. Is this project subject to provisions of the MassDEP Stormwater Management Standards?
 a. Yes. Attach a copy of the Stormwater Report as required by the Stormwater Management Standards per 310 CMR 10.05(6)(k)-(q) and check if:
 1. Applying for Low Impact Development (LID) site design credits (as described in Stormwater Management Handbook Vol. 2, Chapter 3)
 2. A portion of the site constitutes redevelopment
 3. Proprietary BMPs are included in the Stormwater Management System.
 b. No. Check why the project is exempt:
 1. Single-family house
 2. Emergency road repair
 3. Small Residential Subdivision (less than or equal to 4 single-family houses or less than or equal to 4 units in multi-family housing project) with no discharge to Critical Areas.

D. Additional Information

- This is a proposal for an Ecological Restoration Limited Project. Skip Section D and complete Appendix A: Ecological Restoration Notice of Intent – Minimum Required Documents (310 CMR 10.12).

Applicants must include the following with this Notice of Intent (NOI). See instructions for details.

Online Users: Attach the document transaction number (provided on your receipt page) for any of the following information you submit to the Department.

1. USGS or other map of the area (along with a narrative description, if necessary) containing sufficient information for the Conservation Commission and the Department to locate the site. (Electronic filers may omit this item.)
2. Plans identifying the location of proposed activities (including activities proposed to serve as a Bordering Vegetated Wetland [BVW] replication area or other mitigating measure) relative to the boundaries of each affected resource area.



Massachusetts Department of Environmental Protection
 Bureau of Resource Protection - Wetlands
WPA Form 3 – Notice of Intent
 Massachusetts Wetlands Protection Act M.G.L. c. 131, §40

Provided by MassDEP:

MassDEP File Number

Document Transaction Number

City/Town

D. Additional Information (cont'd)

- 3. Identify the method for BVW and other resource area boundary delineations (MassDEP BVW Field Data Form(s), Determination of Applicability, Order of Resource Area Delineation, etc.), and attach documentation of the methodology.
- 4. List the titles and dates for all plans and other materials submitted with this NOI.
 - Site Plan 4 Nipmuc Drive Mendon, Massachusetts
 - a. Plan Title _____
 - Guerriere & Halnon, Inc. _____ Elizabeth Mainini-Sanchioni _____
 - b. Prepared By _____ c. Signed and Stamped by _____
 - March 19, 2021 _____ 1"=30' _____
 - d. Final Revision Date _____ e. Scale _____
 - f. Additional Plan or Document Title _____ g. Date _____
- 5. If there is more than one property owner, please attach a list of these property owners not listed on this form.
- 6. Attach proof of mailing for Natural Heritage and Endangered Species Program, if needed.
- 7. Attach proof of mailing for Massachusetts Division of Marine Fisheries, if needed.
- 8. Attach NOI Wetland Fee Transmittal Form
- 9. Attach Stormwater Report, if needed.

E. Fees

- 1. Fee Exempt: No filing fee shall be assessed for projects of any city, town, county, or district of the Commonwealth, federally recognized Indian tribe housing authority, municipal housing authority, or the Massachusetts Bay Transportation Authority.

Applicants must submit the following information (in addition to pages 1 and 2 of the NOI Wetland Fee Transmittal Form) to confirm fee payment:

22457 _____	March 18, 2021 _____
2. Municipal Check Number	3. Check date
22458 _____	March 18, 2021 _____
4. State Check Number	5. Check date
Remodeling Remedies, LLC Barbara _____	Leland _____
6. Payor name on check: First Name	7. Payor name on check: Last Name



Massachusetts Department of Environmental Protection
 Bureau of Resource Protection - Wetlands
WPA Form 3 – Notice of Intent
 Massachusetts Wetlands Protection Act M.G.L. c. 131, §40

Provided by MassDEP:

MassDEP File Number
Document Transaction Number
City/Town

F. Signatures and Submittal Requirements

I hereby certify under the penalties of perjury that the foregoing Notice of Intent and accompanying plans, documents, and supporting data are true and complete to the best of my knowledge. I understand that the Conservation Commission will place notification of this Notice in a local newspaper at the expense of the applicant in accordance with the wetlands regulations, 310 CMR 10.05(5)(a).

I further certify under penalties of perjury that all abutters were notified of this application, pursuant to the requirements of M.G.L. c. 131, § 40. Notice must be made by Certificate of Mailing or in writing by hand delivery or certified mail (return receipt requested) to all abutters within 100 feet of the property line of the project location.

[Handwritten Signature]

1. Signature of Applicant

3.19.21

2. Date

3. Signature of Property Owner (if different)

Amanda Coushner

4. Date

3/19/2021

5. Signature of Representative (if any)

6. Date

For Conservation Commission:

Two copies of the completed Notice of Intent (Form 3), including supporting plans and documents, two copies of the NOI Wetland Fee Transmittal Form, and the city/town fee payment, to the Conservation Commission by certified mail or hand delivery.

For MassDEP:

One copy of the completed Notice of Intent (Form 3), including supporting plans and documents, one copy of the NOI Wetland Fee Transmittal Form, and a **copy** of the state fee payment to the MassDEP Regional Office (see Instructions) by certified mail or hand delivery.

Other:

If the applicant has checked the "yes" box in any part of Section C, Item 3, above, refer to that section and the Instructions for additional submittal requirements.

The original and copies must be sent simultaneously. Failure by the applicant to send copies in a timely manner may result in dismissal of the Notice of Intent.



Massachusetts Department of Environmental Protection
 Bureau of Resource Protection - Wetlands
NOI Wetland Fee Transmittal Form
 Massachusetts Wetlands Protection Act M.G.L. c. 131, §40

Important: When filling out forms on the computer, use only the tab key to move your cursor - do not use the return key.



A. Applicant Information

1. Location of Project:

4 Nipmuc Drive

a. Street Address

Mendon

b. City/Town

c. Check number

d. Fee amount

2. Applicant Mailing Address:

Barbara

a. First Name

Leland

b. Last Name

Jason LLC

c. Organization

P.O. Box 444

d. Mailing Address

Mendon

e. City/Town

MA.

f. State

01756

g. Zip Code

508-962-4452

h. Phone Number

i. Fax Number

barnam@verizon.net

j. Email Address

3. Property Owner (if different):

a. First Name

b. Last Name

c. Organization

d. Mailing Address

e. City/Town

f. State

g. Zip Code

h. Phone Number

i. Fax Number

j. Email Address

B. Fees

Fee should be calculated using the following process & worksheet. ***Please see Instructions before filling out worksheet.***

Step 1/Type of Activity: Describe each type of activity that will occur in wetland resource area and buffer zone.

Step 2/Number of Activities: Identify the number of each type of activity.

Step 3/Individual Activity Fee: Identify each activity fee from the six project categories listed in the instructions.

Step 4/Subtotal Activity Fee: Multiply the number of activities (identified in Step 2) times the fee per category (identified in Step 3) to reach a subtotal fee amount. Note: If any of these activities are in a Riverfront Area in addition to another Resource Area or the Buffer Zone, the fee per activity should be multiplied by 1.5 and then added to the subtotal amount.

Step 5/Total Project Fee: Determine the total project fee by adding the subtotal amounts from Step 4.

Step 6/Fee Payments: To calculate the state share of the fee, divide the total fee in half and subtract \$12.50. To calculate the city/town share of the fee, divide the total fee in half and add \$12.50.

To calculate filing fees, refer to the category fee list and examples in the instructions for filling out WPA Form 3 (Notice of Intent).



Massachusetts Department of Environmental Protection
 Bureau of Resource Protection - Wetlands
NOI Wetland Fee Transmittal Form
 Massachusetts Wetlands Protection Act M.G.L. c. 131, §40

B. Fees (continued)

Step 1/Type of Activity	Step 2/Number of Activities	Step 3/Individual Activity Fee	Step 4/Subtotal Activity Fee
category 1 b	1	\$110.00	\$110.00
_____	_____	_____	_____
_____	_____	_____	_____
_____	_____	_____	_____
_____	_____	_____	_____
_____	_____	_____	_____
_____	_____	_____	_____
_____	_____	_____	_____
Step 5/Total Project Fee:			<u>\$110.00</u>
Step 6/Fee Payments:			
Total Project Fee:			<u>\$110.00</u>
State share of filing Fee:			<u>\$42.50</u>
City/Town share of filling Fee:			<u>\$67.50</u>
			a. Total Fee from Step 5
			b. 1/2 Total Fee less \$12.50
			c. 1/2 Total Fee plus \$12.50

C. Submittal Requirements

- a.) Complete pages 1 and 2 and send with a check or money order for the state share of the fee, payable to the Commonwealth of Massachusetts.

Department of Environmental Protection
 Box 4062
 Boston, MA 02211

- b.) **To the Conservation Commission:** Send the Notice of Intent or Abbreviated Notice of Intent; a **copy** of this form; and the city/town fee payment.

To MassDEP Regional Office (see Instructions): Send a copy of the Notice of Intent or Abbreviated Notice of Intent; a **copy** of this form; and a **copy** of the state fee payment. (E-filers of Notices of Intent may submit these electronically.)

**Notice of Intent
Project Narrative
4 Nipmuc Drive
Mendon, Massachusetts**

Background:

The project site is located at 4 Nipmuc Drive and consists of an existing 4-bedroom house, garage, driveway and associated utilities.

Project Description:

The Applicant is proposing to construct a 10.5' x 22' carport outside the buffer zone as well as install a 12'x31.5' floating/removable dock along the shores of Nipmuc Pond for the property located at 4 Nipmuc Drive in Mendon, Massachusetts. The dock consists of nine 4'x10.5' removable panels that are placed on an aluminum frame. The frame consists of legs and footpads that will be located within the pond, but are not permanently embedded within the pond bed. Installation instructions from the manufacturer Shoremaster are attached for your reference.

Additional activities will consist of clearing approximately 10' wide x 50' long area (500 square feet) within 25 feet of the pond to place sand or pea stone and a path with 5' wide stairs transitioning from the yard down to the water.

Mitigation Measures:

The proposed construction activities within 25' of Nipmuc Pond will be surrounded by erosion control consisting of mulch sock and silt fence to minimize potential impacts to the pond and surrounding areas during construction.

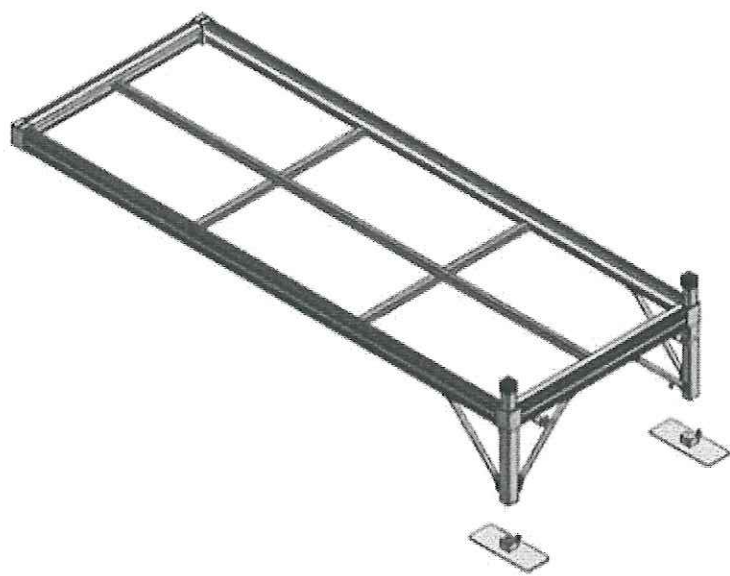

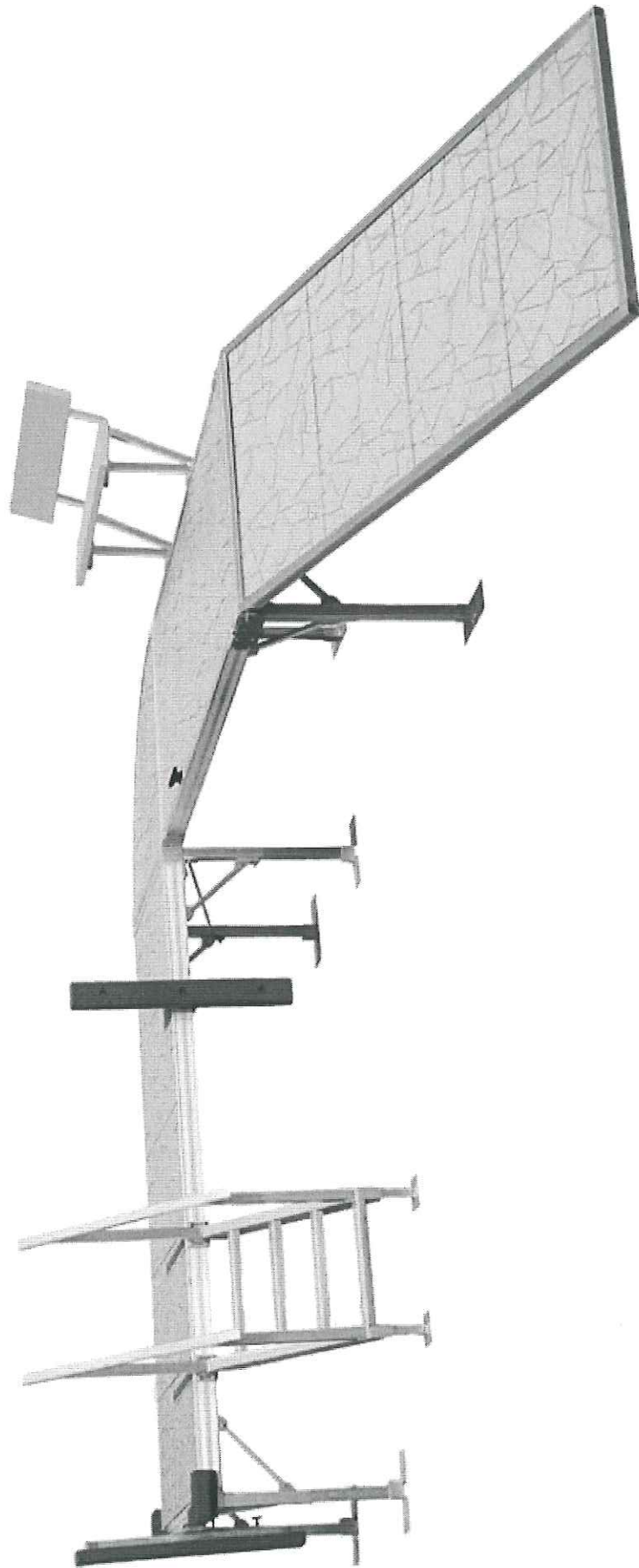

SHOREMASTER DOCK SECTIONS

Instructions and Safety Tips



Infinity
RS4



Infinity
TS9



Infinity
RS7



Floating
FTS9

WARNING - PUT SAFETY FIRST

To prevent serious personal injury or death, study and fully understand the proper operating procedures and safety precautions outlined in this owner's manual before attempting to install or use this dock. If you have any questions about assembly, installation, use or suitability of this product, contact an authorized dealer.

- NOT COMPLYING WITH THE PROCEDURES AND PRECAUTIONS OUTLINED IN THIS MANUAL MAY RESULT IN PERSONAL INJURY OR DEATH AND WILL INVALIDATE THE WARRANTY.
- To avoid personal injury do not run on dock or dive off the dock. Running on dock could result in a falling injury. Diving off dock could result in a severe head, neck, or back injury or death. Use caution, especially when surface is wet.
- To avoid personal injury wear protective gloves, clothing and safety glasses when assembling and installing the dock.
- Do not drop parts in the water. Please remove any Leg Caps or other parts from lake bottom to avoid injury.
- Be sure your dock can be installed on a firm and stable foundation. If lake bottom does not allow for a secure installation, this product may not be suitable. ShoreMaster builds a wide variety of docks. Call your dealer for suggestions or other options.
- Install high enough above water surface, so waves do not contact Dock Frames or Panels.
- Read and fully understand each step before proceeding with that step.
- Do not assemble, install or use this product if items are missing or damaged.

Shoremaster Dock Systems

RS4 Sections

Part Numbers:

- 4 x 4 Section --- 1005988
- 4 x 10 Section - 1005986
- 4 x 12 Section - 1005987
- 6 x 8 Section --- 1005989
- Corner Frame - 1005990

RS7 Sections

Part Numbers:

- 4 x 8 Section --- 1003955
- 4 x 12 Section - 1026568
- 4 x 16 Section - 1003956
- 6 x 8 Section --- 1017105
- 6 x 16 Section - 1017106
- Corner Frame - 1005991

TS9 Sections

Part Numbers:

- 4 x 8 Section --- 1003959
- 4 x 16 Section - 1003958
- 6 x 8 Sections - 1017108
- 6 x 16 Section - 1003964
- Corner Frame - 1005994

FTS9

Part Numbers:

- 4 x 2 Section --- 1003701
- 4 x 4 Section --- 1003702
- 4 x 8 Section --- 1003699
- 4 x 16 Section - 1003700
- 6 x 8 Section --- 1003703
- 6 x 16 Section - 1003714

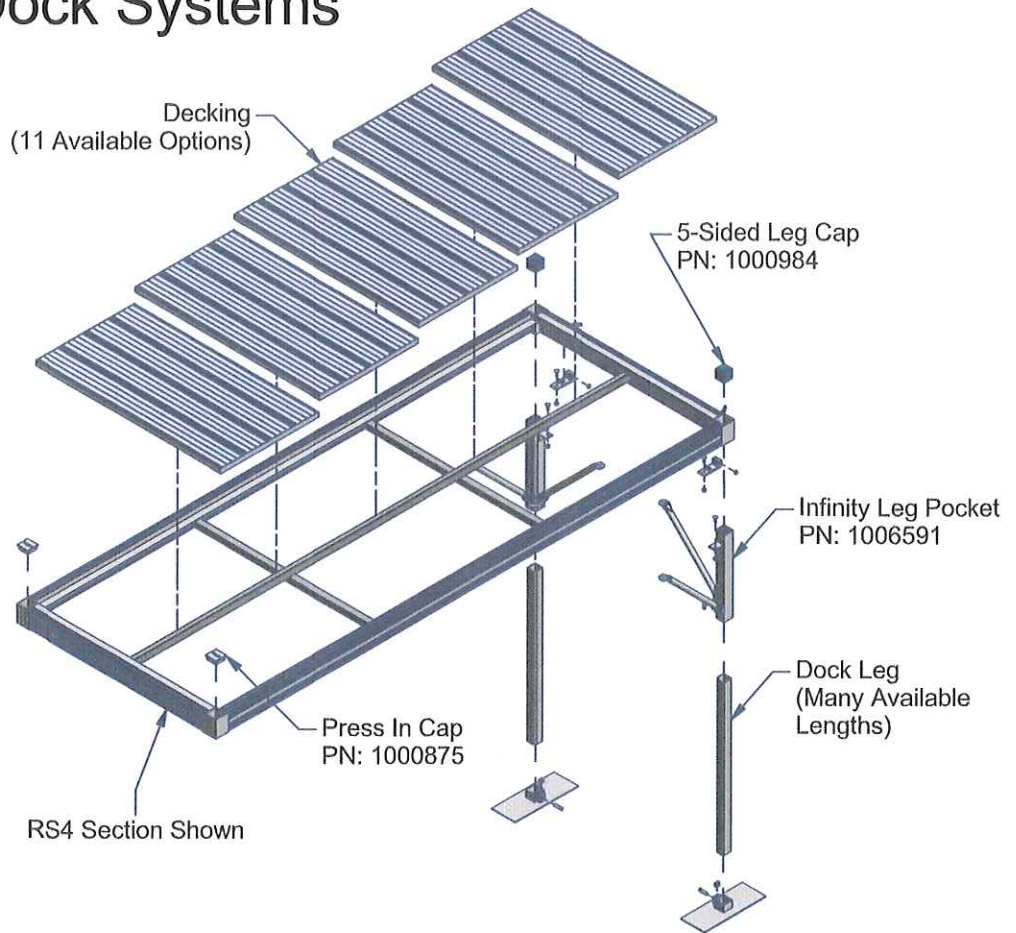

Decking Type

- Ipe Hardwood
- Traditional Woodgrain Aluminum
- Gray Oak Woodgrain Aluminum
- Tan Vertex
- Gray Vertex
- Tan Flow Through
- Gray Flow Through
- Tan Painted Aluminum
- White Painted Aluminum
- Plain Aluminum
- Cedar

<u>Leg Posts</u>	<u>PART #</u>
3' DOCK LEG POST (each)	- 1003556
5' DOCK LEG POST (each)	- 1000157
7' DOCK LEG POST (each)	- 1000158
9' DOCK LEG POST (each)	- 1000159
12' DOCK LEG POST (each)	- 1000160

INFINITY DOCK SYSTEMS

RS4 Dock Corner - 3ft

Part #: 1005990

Parts List			
ITEM	QTY	PART NUMBER	DESCRIPTION
1	1	1003779	Uni-Dock Corner Frame 2005
-	1	1004427	Bolt Bag Corner RS4
2	4	1001802	Nut Flange 3/8-16 Alum
3	4	1001803	Nut Hex 3/8-16 Brass
4	4	1004651	Dock Connector - 1.5
5	4	1001956	Bolt Carriage 3/8-16 x 1.0 SS 304
6	4	1026428	T Handle .375-16 X 1.5 X 2.5
7	1	-	Corner Panel

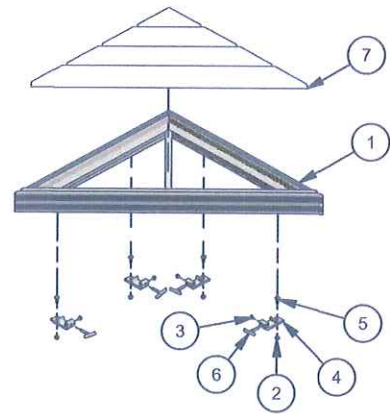

RS4 Curved Dock - 45°

Part #: 1003953

Parts List			
ITEM	QTY	PART NUMBER	DESCRIPTION
1	1	-	Panel Curve Dock 45 deg
-	1	1004426	Bolt Bag 45/90 RS4 Curve Dock
2	2	1001802	Nut Flange 3/8-16 Alum
3	2	1001803	Nut Hex 3/8-16 Brass
4	2	1004651	Dock Connector - 1.5
5	2	1001956	Bolt Carriage 3/8-16 x 1.0 SS 304
6	4	1000875	Plastic Cap w/ Logo - for Dock Pockets
7	2	1026428	T Handle .375-16 X 1.5 X 2.5
8	1	1003689	Wdmt Frame 45 Degree Curve Dock RS4

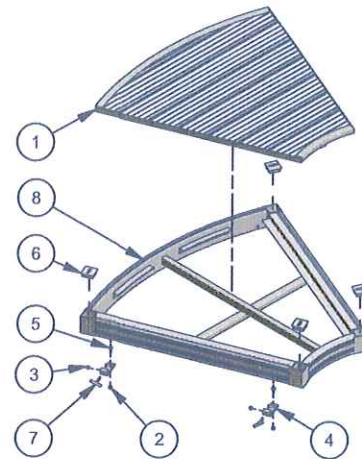

RS4 Curved Dock - 90°

Part #: 1003954

Parts List			
ITEM	QTY	PART NUMBER	DESCRIPTION
1	1	1003690	Frame 90 (RS4) Curve Dock
2	1	-	Panel Curve Dock 90 deg
-	1	1004426	Bolt Bag 45/90 RS4 Curve Dock
3	2	1001802	Nut Flange 3/8-16 Alum
4	2	1001803	Nut Hex 3/8-16 Brass
5	2	1004651	Dock Connector - 1.5
6	2	1001956	Bolt Carriage 3/8-16 x 1.0 SS 304
7	4	1000875	Plastic Cap w/ Logo - for Dock Pockets
8	2	1026428	T Handle .375-16 X 1.5 X 2.5

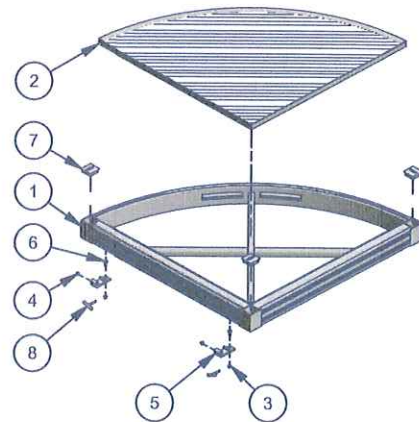

ASSEMBLY INSTRUCTIONS

Note: RS4 dock shown for example. Connections also apply for RS7 and TS9.

Tools needed:

1. 9/16" Wrench
2. Measuring Tape
3. Optional - Carpenter's Level

Tips:

Before assembly determine the layout of the dock system. Take depth measurements at ten foot intervals starting at where the dock will start. Have adequate dock leg lengths to accommodate water fluctuation and waves. For ease of assembly find a flat area with sufficient room to assemble dock.

STEP 1

After determining the layout of your dock system, install all leg pockets according to their instructions. The number and location of leg pockets will depend on the specific layout and the type of leg posts.

STEP 2

Attach one foot pad to each leg post. Secure leg post with one 1/2 x 1-1/4 Set screw and one 1/2 square nut per leg.

Note: Leg posts are ordered separately from dock section because of varying lengths needed.

STEP 3

Determine which side of the dock frame will be connected to other sections. Insert one 3/8 Nut into each Connector Clip and thread the 3/8 x 1-1/2 T-Handle through it just so they stay together - as shown in Detail "A".

Attach connector clips to the rail. Secure with one 3/8 x 1 carriage bolt and one 3/8 flange nut. The carriage bolt head inserts into the opening in the bottom slot of the rail and attaches to the connector clip - as shown in Detail "A".

Place the connector clip six inches or less in from the corner - as shown in Detail "B".

NOTICE A rail six feet or less requires two connector clips. Rails greater than six feet need a third connector in the middle of the connection for proper stability.

WARNING Make sure the connector clip assembly is fully clear of the opening in the slot. If the t-handle is threaded into the opening of the slot before the dock frame is set in place, it will prevent proper securing of the dock sections and may lead to physical injury.

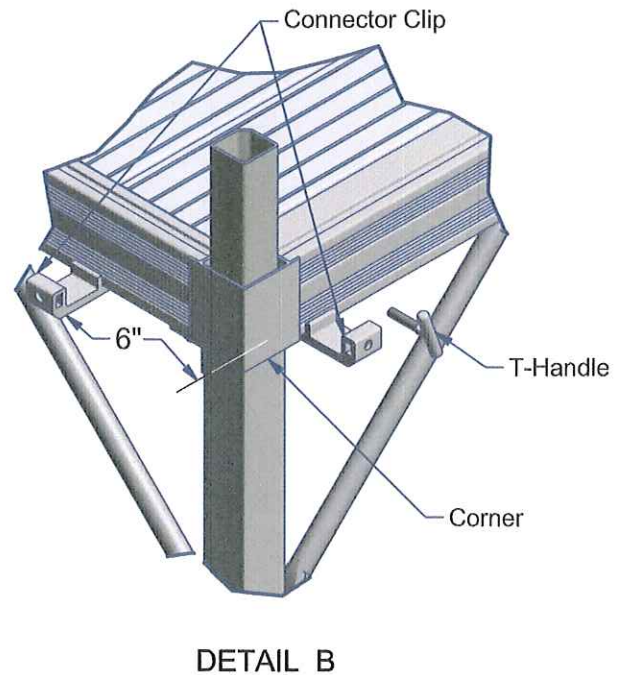
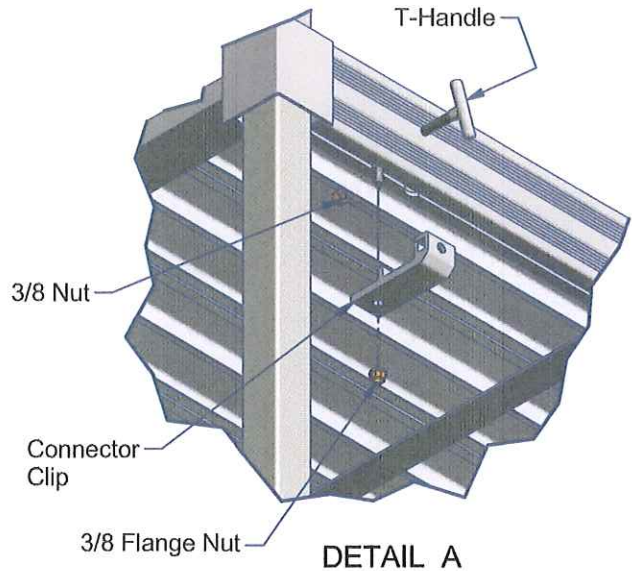

INFINITY DOCK SYSTEMS

STEP 4

Now the first frame can be carried into place. Place the second frame into the connector clips of the first - as shown to the right.

⚠ WARNING To avoid personal injury the connector clips must be bolted to a dock frame that is supported by legs. The unsupported end of the attaching dock frame will set into the connector clip. If the connector clip is bolted to the dock frame that is not supported by legs the dock section may come loose and fall, causing injury.

Secure by tightening the 3/8 x 1-1/2 T-Handle - as shown in Detail "A".

Note: Two connector clips are needed if connecting to an end rail. Three are needed if connecting two side rails together.

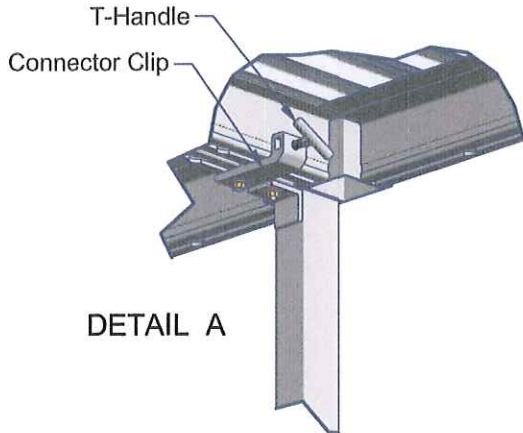
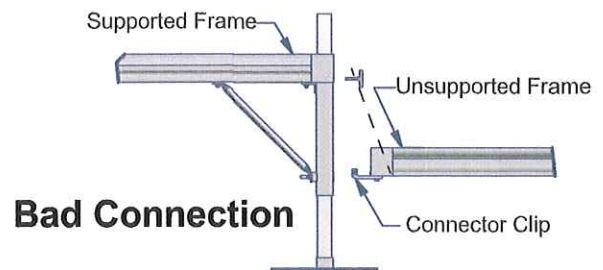
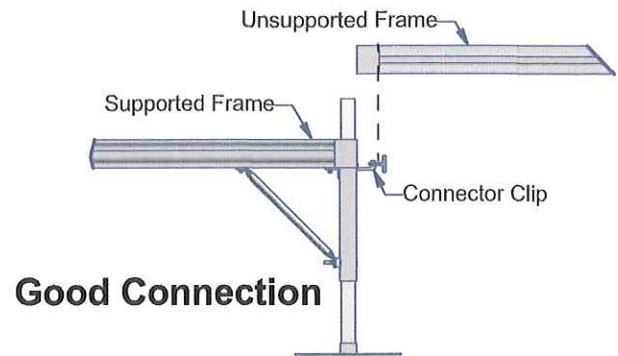

STEP 5

When all dock frames are in place, adjust the level of the dock sections as needed using the adjustable leg posts.

Note: Make sure there is enough clearance for water fluctuation and wave action.

Fully tighten all Nuts and Bolts.

Note: Do not over tighten set screws. Over tightening of set screws will result in bending or breaking of parts.

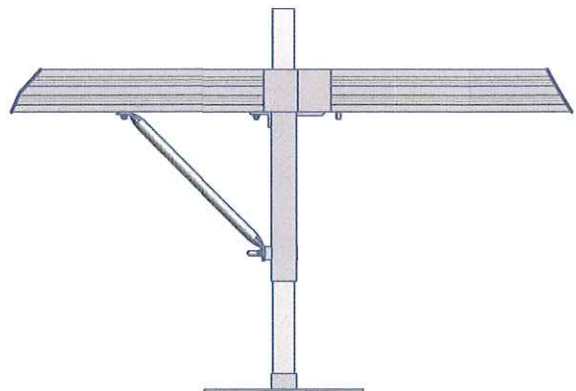

Common Dock Accessories

(More Options Available)



Dock Steps

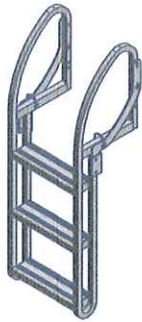

Pivoting Ladder



LakeView Rhino Bench (Off Deck)

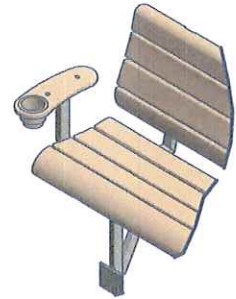

LakeView Bench Armrest

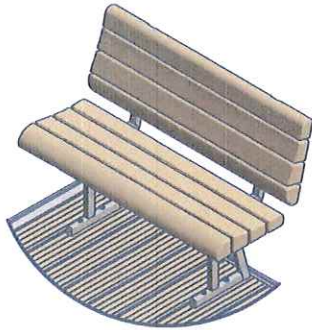

LakeView Rhino Bench (On Deck)



Vertical Bumper



Fishing Rod Holder



Flagpole Holder



Umbrella Holder

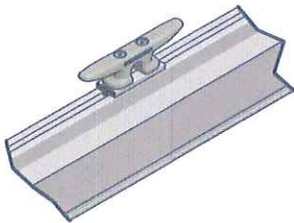

Cleat Kit



Wheel/Axle Adapter for 2 x 2 Dock Legs



Canoe/Kayak Rack

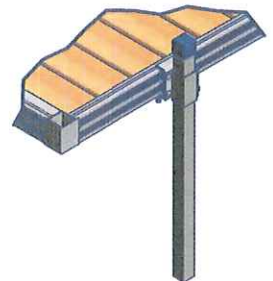

Leg Pocket Add-On Bracket

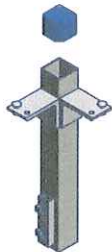

Single Leg Pocket



Furniture Hardware Box

STEP 6

Leg caps are included for each corner tube that is not used or does not have a leg post above the deck surface - as shown below.

NOTE: To avoid cracking the press in caps it is best to use a large rubber mallet to install. Start by lightly tapping around the edges until the cap is completely fit into the leg pocket.

The leg posts that are above the deck surface may be covered with a blue cap - as shown below.

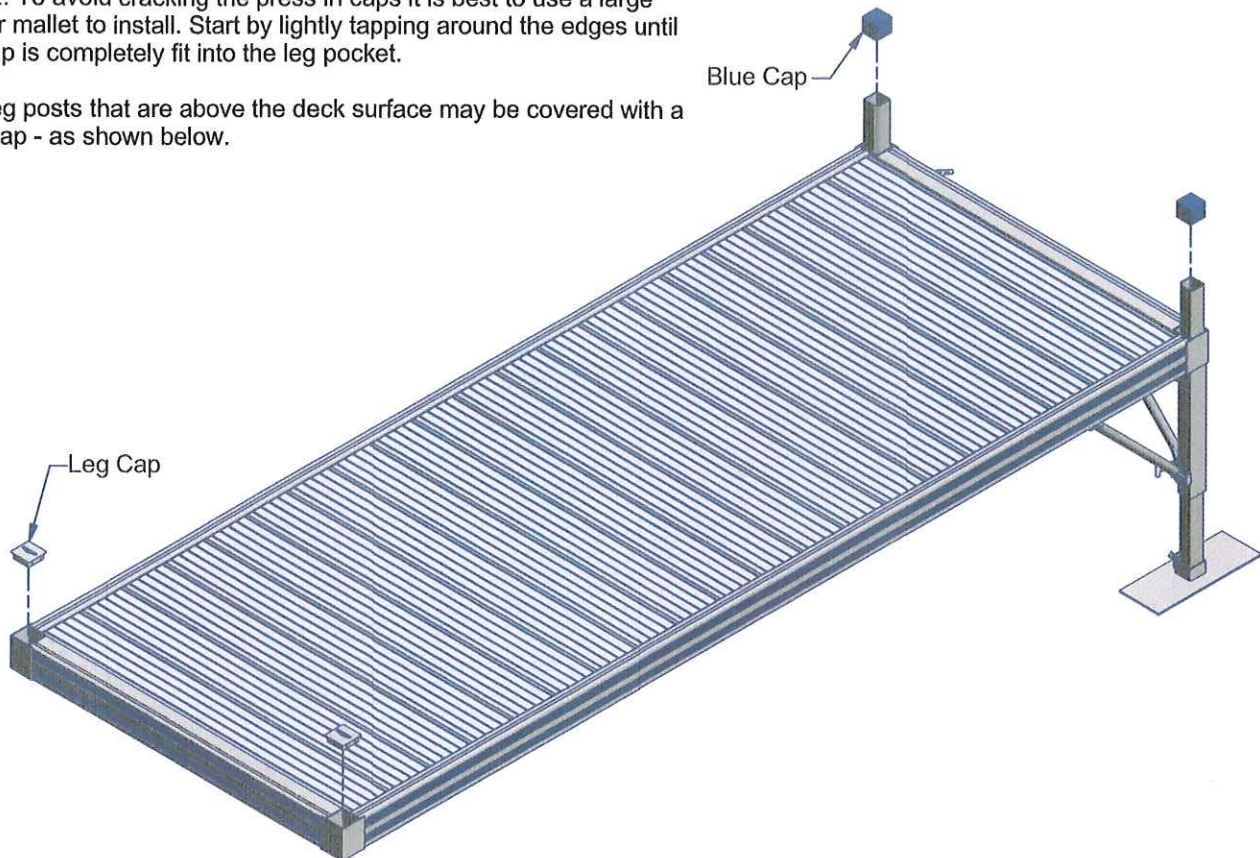

USE, REMOVAL, STORAGE AND SERVICE

▪Upon completed installation, your dock system is ready for use. **Many ShoreMaster dock accessories are available to compliment your dock system.** Contact your dealer for available options.

NOTICE The dock system must be removed from water during the winter months. Warranty is void if dock is exposed to ice conditions.

▪You may remove each frame with panels in place, or you can remove the panels before detaching the frames. Stack panels on a flat surface, and store them in a dry area to preserve life.

▪Inspect frames, panels, connections, nuts, and bolts at least once every six months for damage, wear or loose connections. Tighten or replace parts as needed.

▪ShoreMaster dealers usually offer service visits. Please contact them if you are unable or unwilling to perform service to docks.

Accessory Connection System

The RS4, RS7, TS9, and FTS9 ShoreMaster dock systems have many accessory options. Contact your dealer or visit www.shopshoremaster.com to purchase available accessories.

The accessory connection system works by utilizing a built in connection system on the dock frame and accessory connectors to securely fasten any accessory to the dock. There are three accessory connectors available. One for RS4, one for RS7, and one for the TS9 and FTS9. The accessory connectors come with four carriage bolts and flange nuts to secure the accessory to the accessory connector.

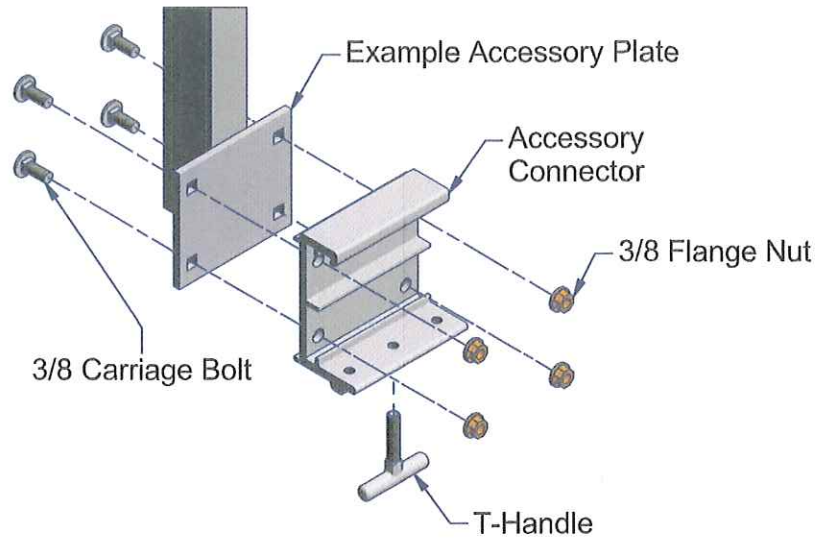

Installation is quick and easy. Simply secure the accessory connector to the accessory plate using the provided carriage bolts and flange nuts. Slip the top flange of the accessory connector into the top slot on the dock frame and hinge so it is tight against the dock frame. Thread the provided t-handle into the bottom of the connector so that the t-handle locks into the slot in the bottom of the dock frame.

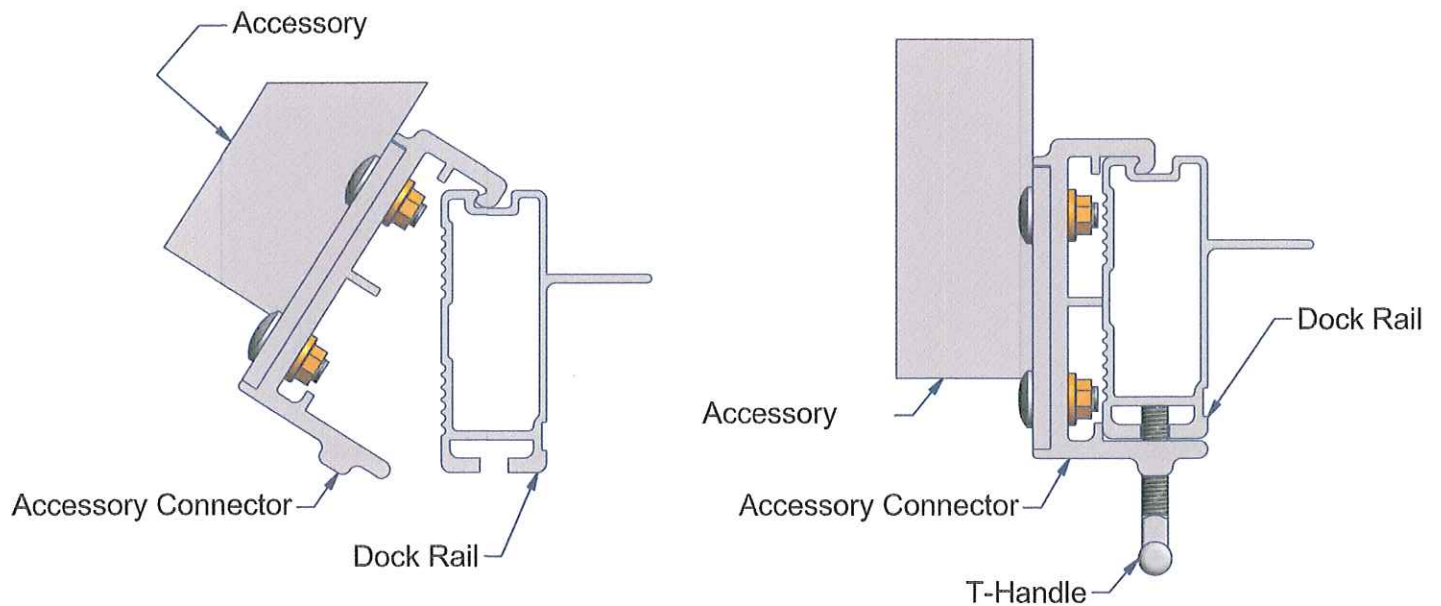

Mendon, MA



3/11/2021, 11:09:02 AM

- Property Parcels
- Mendon Level 3 Parcel Data - Other Legal
- EASE
- FEE
- Mendon Level 3 Parcel Data - Misc.
- WETLAND

1:2,257

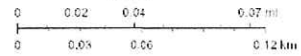

Esri, HERE, Garmin, INCREMENT P, NOAA, USGS, MassGIS, MassGIS, Esri, Canada, Esri, HERE, Garmin, INCREMENT P, USGS, EPA, USGS

Map created by:
Information depicted on this map is for planning purposes only.

Assessor Map

4 Nipmuc Drive Mendon, MA.

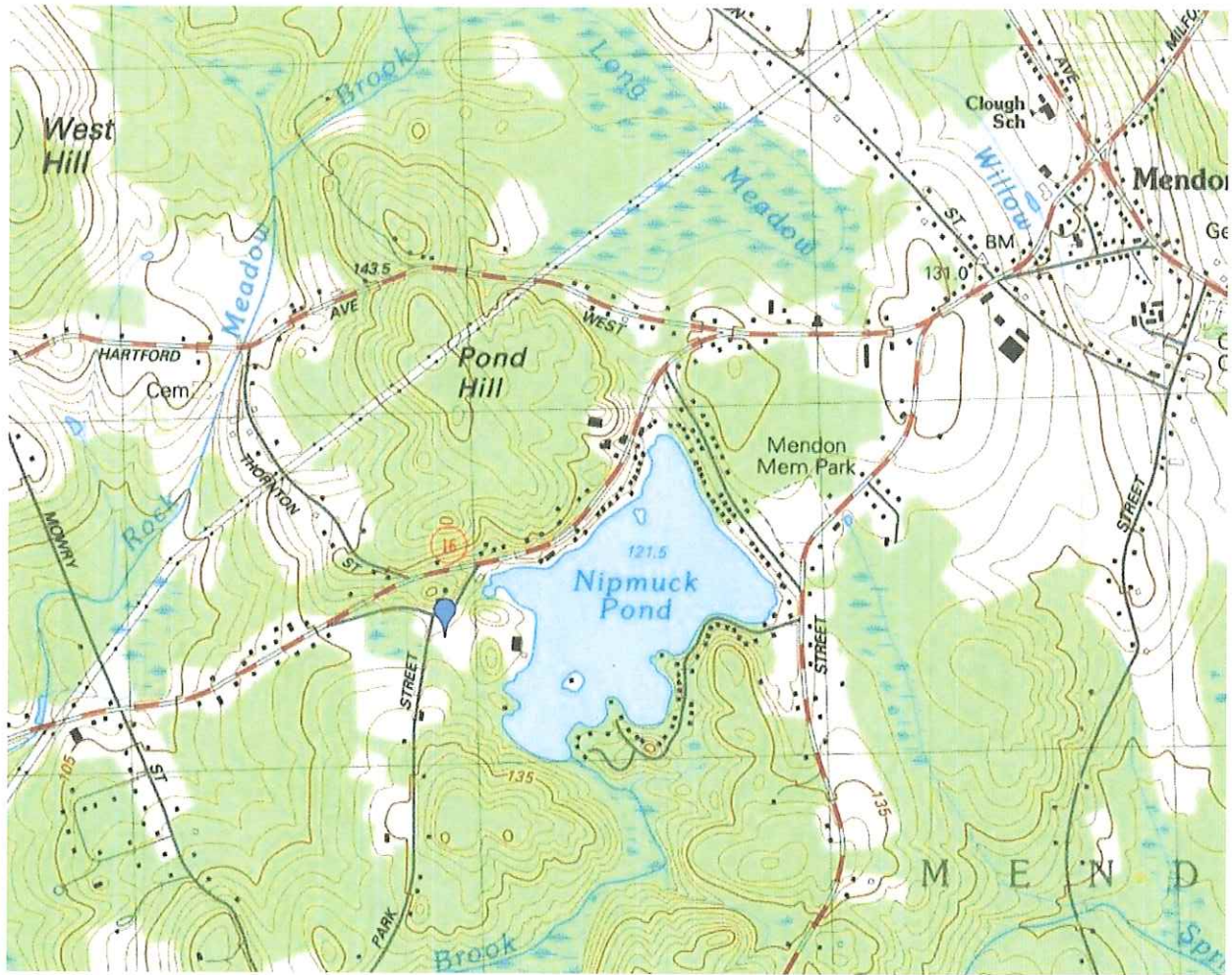

Mendon Quadrangle Map

4 Nipmuck Drive

Mendon, MA.



**Guerriere &
Halton, Inc.**
ENGINEERING & LAND SURVEYING



Natural Heritage Endangered Species Estimated Habitat Map

For

4 Nipmuc Drive

Mendon, MA.



**Guerriere &
Halnon, Inc.**
ENGINEERING & LAND SURVEYING



Legend

Pin: Approximate location based on user input and does not represent an authoritative property location

MAP PANELS:

- Selected Floormap Boundary
- Digital Data Available
- No Digital Data Available
- Unmapped

OTHER AREAS:

- NO SCENARIO: Area of Minimal Flood Hazard Zone X
- Effective LDMs
- Area of undetermined Flood Hazard Zone 0
- Otherwise Protected Area
- Coastal Barrier Resource System Area

SPECIAL FLOOD HAZARD AREAS:

- Without Base Flood Elevation (BFE) Zone AE, V, X, ZONE
- With BFE or Depth Regulatory Floodway Zone AE, AO, AH, VE, AR
- 0.2% Annual Chance Flood Hazard, Areas of 1% annual chance flood with average depth less than one foot or with drainage areas of less than one square mile Zone X
- Future Conditions 1% Annual Chance Flood Hazard Zone X
- Area with Reduced Flood Risk due to Levee, See Notes, Zone X
- Area with Flood Risk due to Levee Zone 0

OTHER AREAS OF FLOOD HAZARD:

- Without Base Flood Elevation (BFE) Zone AE, V, X, ZONE
- With BFE or Depth Regulatory Floodway Zone AE, AO, AH, VE, AR

OTHER FEATURES:

- 20.2 Cross Sections with 1% Annual Chance Water Surface Elevation
- 22.4 Coastal Transect
- Base Flood Elevation Line (BFE)
- Limit of Study
- Jurisdiction Boundary
- Coastal Transect Baseline
- Profile Baseline
- Hydrographic Feature

GENERAL STRUCTURES:

- Channel, Culvert, or Storm Sewer
- Levee, Dike, or Floodwall

FEMA MAP
 4 Nipmuc Drive
 Mendon, MA.



Guerriere & Halnon, Inc.
 ENGINEERING & LAND SURVEYING

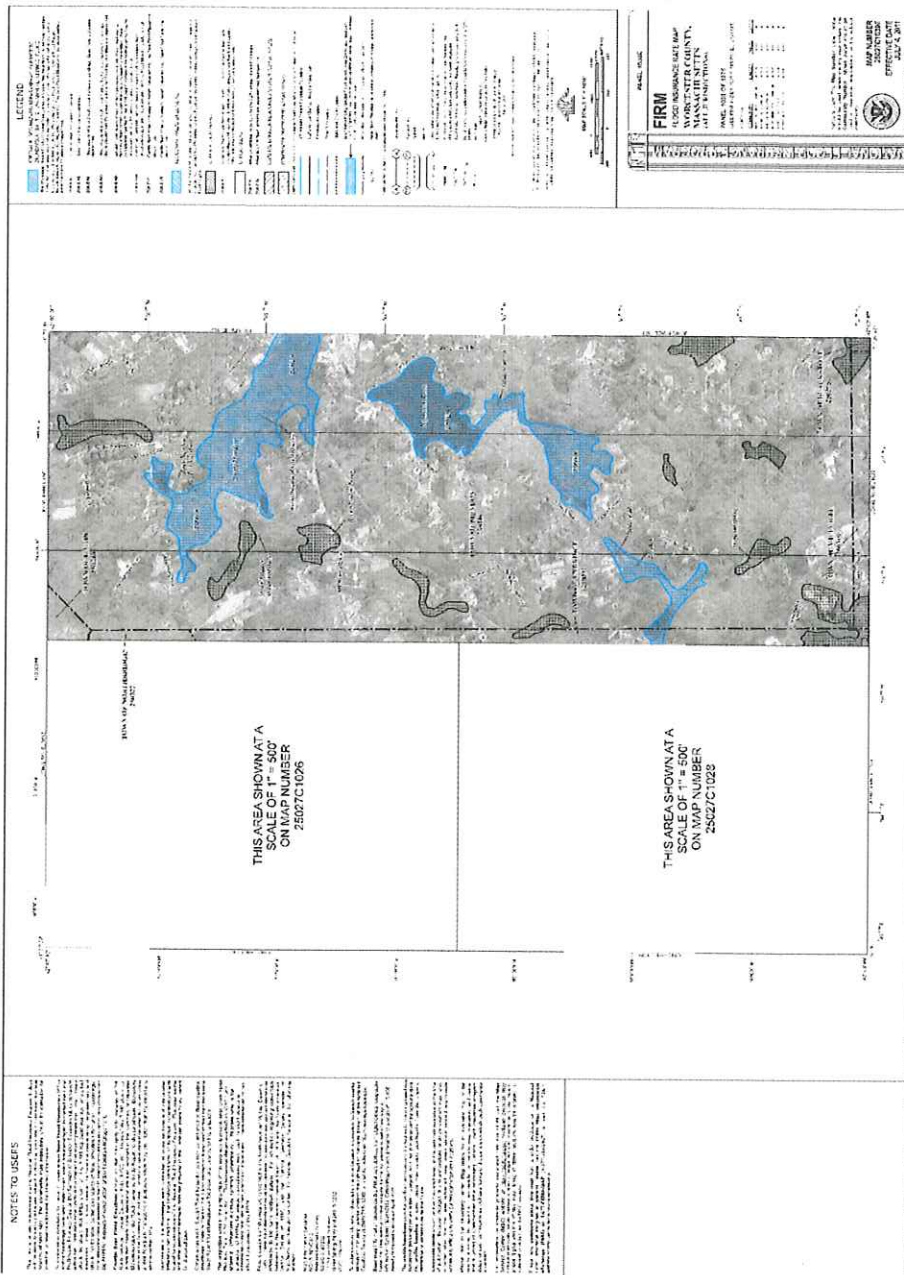

**Guerriere &
 Halnon, Inc.**
 ENGINEERING & LAND SURVEYING

FEMA MAP-4 Nipmuc Drive Mendon, MA.

**Notification to Abutters
Under the Massachusetts Wetlands Protection Act**

In accordance with the second paragraph of the Massachusetts General Laws Chapter 131, Section 40, you are hereby notified of the following:

The name of the applicant is: Jason LLC.

The applicant has filed a Notice of Intent with the Mendon Conservation Commission seeking permission to remove, fill, dredge or alter an Area Subject to Protection Under the Wetlands Protection Act (General Laws Chapter 131, Section 40).

The Notice of Intent is for the following activity: To construct a 10.5' x 22' carport, and stairs, and floating/removable 12' x 31.5' dock.

The address of the lot where the activity is proposed is 4 Nipmuc Drive.

Copies of the Notice of Intent may be examined at the Mendon Conservation Commission Office, 20 Main Street, Mendon, MA 01756 between the hours of 10:00 a.m. and 2:00 p.m., Tuesdays and Thursdays.

Copies of the Notice of Intent and more information may be obtained from either (check one) the applicant _____, or the applicant's representative x, by calling this telephone number (508-) 473 - 6630 between the hours of 7:30 and 4:00 on the following days of the week: Monday- Friday. (Guerriere and Halnon, Inc.)

The Public Hearing will be held in the Mendon Town Hall on April 22, 2021 at 7:15 PM. More information may be obtained from the Mendon Conservation Commission by calling (508) 634-6898.

NOTE: Notice of the public hearing, including the date, time, and place, will be published at least five (5) days in advance of the hearing in the Milford Daily News.

NOTE: Notice of the public hearing, including its date, time, and place, will be posted in the Mendon Town Hall not less than forty-eight (48) hours in advance.

NOTE: You may contact the nearest Department of Environmental Protection Regional Office for more information about this application or the Wetlands Protection Act. To contact DEP, call the Central Region at (508) 792-7650.



Handwritten red scribble, possibly initials or a signature.

TOWN OF MENDON
BOARD OF ASSESSORS
20 Main Street
MENDON, MA 01756
508-473-2738
508-478-8241 (Fax)
e-mail: assessor@mendonma.gov

REQUEST FOR ABUTTERS

Date: 3/18/2021

Name: Barbara Leland

Company: Jason LLC

Address: 4 Nipmuc Drive

Phone Number: 508-962-4452 Email address: barnam@verizon.net

Owner of Subject Property: same as above

Map: 10 Street Code: 188-4 Parcel: 236-106

Ricky A
LELAND
4 NIPMUC

Number of feet from subject required: _____
(if left blank, 300' will be utilized)

11/13/20

Check here for mailing labels Number of sets: 3

63745

Board for which abutters are requested: Conservation Commission

359

Fees: \$1.00 per name on the abutters list - \$1.00 per sheet of labels

****The Board of Assessors reserves 10 working days to provide all certified lists of abutters. This list is valid for 30 days from the date of certification.***



TOWN OF MENDON
BOARD OF ASSESSORS
20 MAIN STREET
MENDON, MA 01756
508-473-2738
508-478-8241 (Fax)
e-mail: assessor@mendonma.gov

March 22, 2021

*PROPERTY LOCATION(S): 4 Nipmuc Drive
Mendon, Massachusetts
Assessor's Map #10-188-4*

PROPERTY OWNER(S): Ricky A. Leland

*OWNER(S) ADDRESS: 4 Nipmuc Drive
Mendon, MA 01756*

*RECORDED: Worcester Registry of Deeds
November 13, 2020
Book #63745
Page #359*

The attached 100' abutter's list is true and accurate to the best of our knowledge.

Sincerely,

*Jean M. Berthold, MAA
Principal Assessor*

Attachment

TOWN OF MENDON, MA
 BOARD OF ASSESSORS
 20 Main Street, Mendon, MA 01756

Abutters List Within 100 feet of Parcel 10/236/106/0 and others

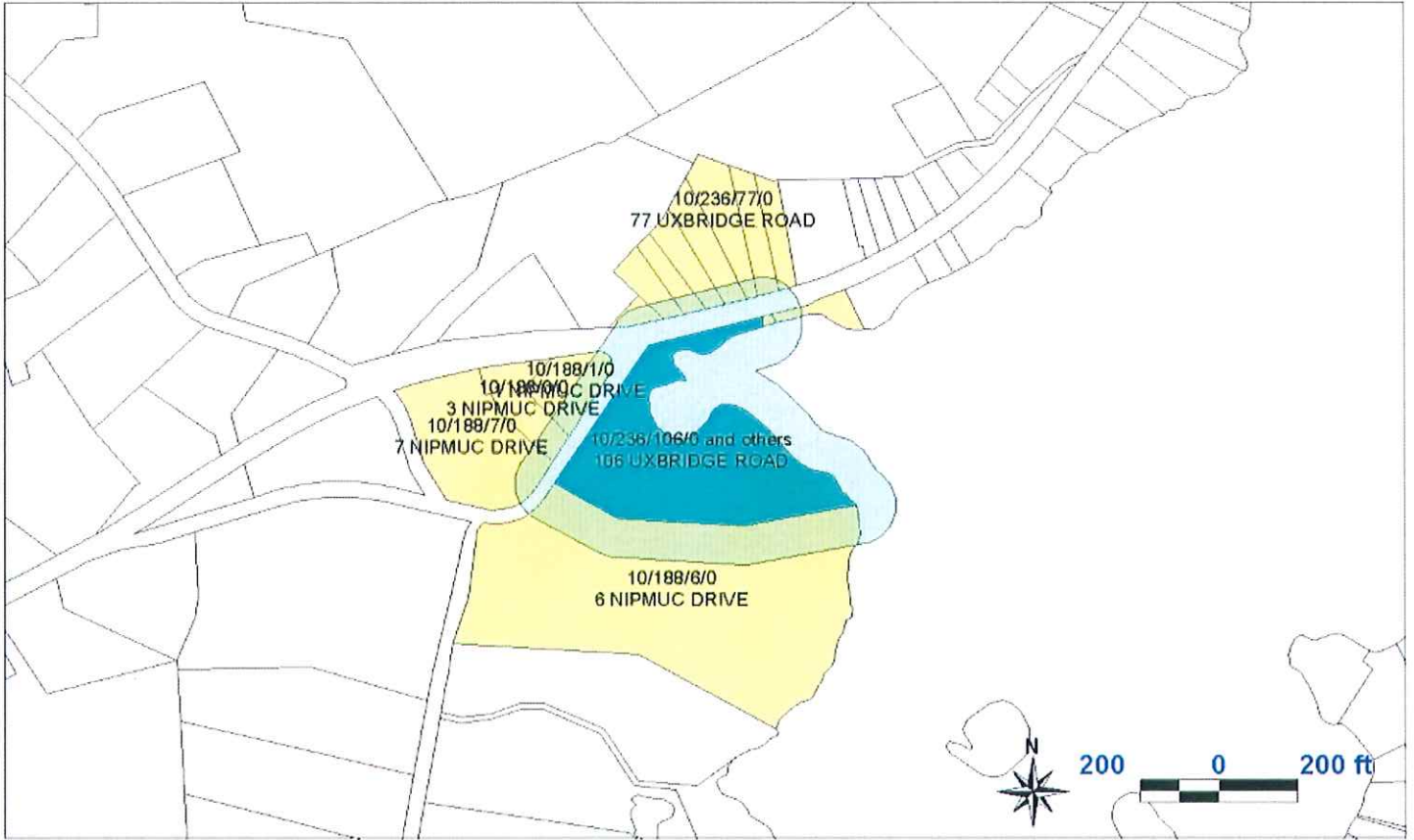

Key	Parcel ID	Owner	Location	Mailing Street	Mailing City	ST	ZipCd/Country
654	10-188-1-0-R	JASON LLC	1 NIPMUC DRIVE	P O BOX 444	MENDON	MA	01756-0444
655	10-188-3-0-R	KEARSLEY GEORGE R & CHERL F	3 NIPMUC DRIVE	P O BOX 274	MENDON	MA	01756
3616	10-188-4-0-R	LELAND RICKY A	4 NIPMUC DRIVE	4 NIPMUC DRIVE	MENDON	MA	01756
3579	10-188-6-0-R	BF GRAND VIEW LLC	6 NIPMUC DRIVE	C/O AVIVA HOSPITALITY GROUP 21 BENNETTS RD, SUITE 101	SETAUKET	NY	11733
656	10-188-7-0-R	PINTO BENTO C	7 NIPMUC DRIVE	6 FRONT STREET	MILFORD	MA	01756
681	10-236-75-0-R	SHAUGHNESSY HAR & SULLIVAN ED C/O ELIZABETH J SHAUGHNESSY	75 UXBRIDGE ROAD (OFF)	90 JONES ROAD	HOPEDALE	MA	01747
705	10-236-75-1-R	FRANKLIN OFFICE PARK REALTY CO	75-1 UXBRIDGE ROAD (OFF)	P O BOX 444	MENDON	MA	01756-0444
682	10-236-77-0-R	DAVIS STEPHEN H	77 UXBRIDGE ROAD	77 UXBRIDGE ROAD	MENDON	MA	01756
683	10-236-79-0-R	BERTONCINI MICHAEL & ZACHARY BRIEN	79 UXBRIDGE ROAD	79 UXBRIDGE ROAD	MENDON	MA	01756
684	10-236-81-0-R	GULINO JENNIFER & RICHARD MARROW	81 UXBRIDGE ROAD	81 UXBRIDGE ROAD	MENDON	MA	01756
685	10-236-83-0-R	FOX DEBORAH A	83 UXBRIDGE ROAD	83 UXBRIDGE ROAD	MENDON	MA	01756
686	10-236-85-0-R	JASON LLC	85 UXBRIDGE ROAD	P O BOX 444	MENDON	MA	01756-0444
687	10-236-86-0-R	ALICANTE PROPERTIES LLC	86 UXBRIDGE ROAD	11 DENAULT DRIVE	BELLINGHAM	MA	02019
688	10-236-87-0-R	JASON LLC	87 UXBRIDGE ROAD	P O BOX 444	MENDON	MA	01756-0444
689	10-236-88-0-R	ALICANTE PROPERTIES LLC	88 UXBRIDGE ROAD	11 DENAULT DRIVE	BELLINGHAM	MA	02019

Key	Parcel ID	Owner	Location	Mailing Street	Mailing City	ST	ZipCd/Country
696	10-236-106-0-R	JASON LLC	106 UXBRIDGE ROAD	P O BOX 444	MENDON	MA	01756-0444