

GOLD MEDALIST LLC
DEED BOOK 516513 PAGE 349
ASSESSORS MA9 14 LOT 23

PLAN BOOK 393 PLAN 96
WORCESTER DISTRICT REGISTRY
OF DEEDS

EXISTING SHED

BETHANY ASSEMBLY OF GOD
DEED BOOK 14136 PAGE 120
ASSESSORS MA9 14 LOT 15

LOT 21
AREA=113,908± S.F.
2.61 ±ACRES

EXISTING SERVICE GARAGE
7,200 sq ft
SLAB 292.93
TOC 293.93

EXISTING CAR WASH
AND DETAIL CENTER
TOC 292.92

VACUUMS

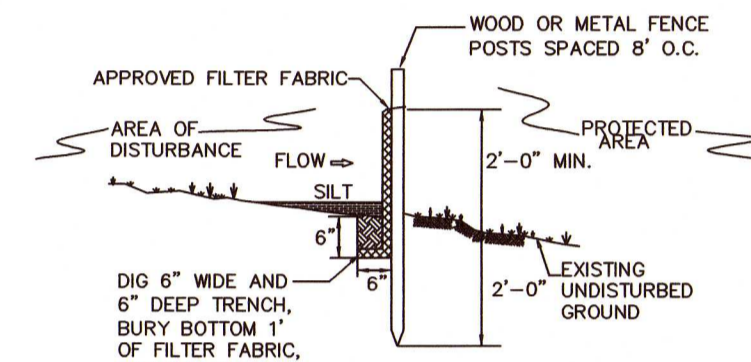

- NOTES:
1. PLACE SILT FENCE AT LOCATIONS AS SHOWN ON THE GRADING AND DRAINAGE PLAN.
 2. SILT FENCE SHALL BE INSTALLED SO WATER CANNOT BYPASS THE FENCE AROUND THE SIDES.
 3. INSPECTION SHALL BE FREQUENT AND REPAIR OR REPLACEMENT SHALL BE MADE AS PROMPTLY AS POSSIBLE IN PLACE FOR THE DURATION OF THE PROJECT UNLESS OTHERWISE INSTRUCTED BY THE CONSERVATION COMMISSION.

SILT FENCE BARRIER

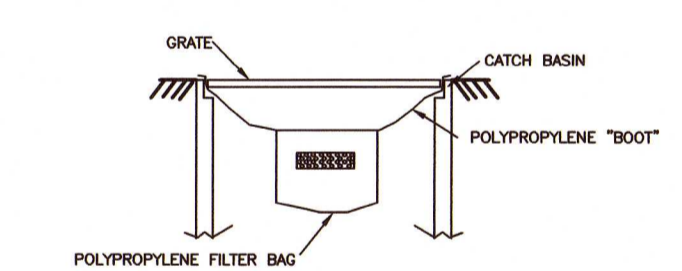

SILTATION BASKET
TYPE II-S (SEDIMENT)
N.T.S.

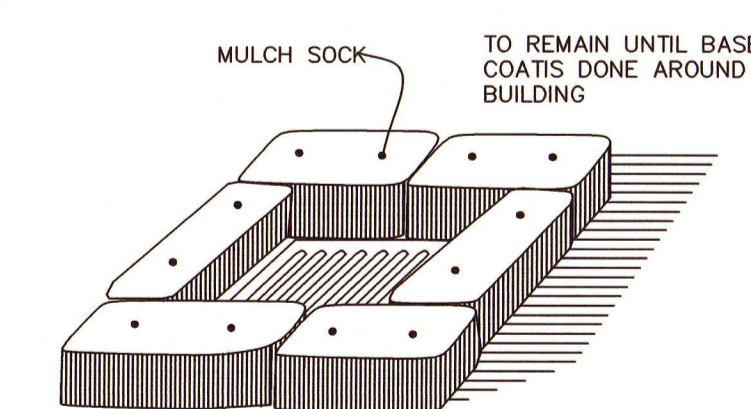

CATCH BASIN FILTER TRAP

PROFESSIONAL ENGINEER _____ DATE _____
SITE PLAN APPROVED
TOWN OF MENDON PLANNING BOARD

DATE: _____
BEING A MAJORITY

NOTE: CONSTRUCTION ON THIS PROJECT IS SUBJECT TO ANY EASEMENTS, RIGHTS-OF-WAY, RESTRICTIONS, RESERVATIONS OR OTHER LIMITATIONS WHICH MAY BE REVEALED BY AN EXAMINATION OF THE TITLE.

DIG SAFE NOTE:
UTILITIES ARE PLOTTED FROM FIELD LOCATION AND ANY RECORD INFORMATION AVAILABLE, AND SHOULD BE CONSIDERED APPROXIMATE. OTHER UTILITIES MAY EXIST WHICH ARE NOT EVIDENT OR FOR WHICH RECORD INFORMATION WAS NOT AVAILABLE. CONTRACTORS IN ACCORDANCE WITH MASS.G.L. CHAPTER 82 SECTION 40 AS AMENDED MUST CONTACT ALL UTILITY COMPANIES BEFORE EXCAVATING AND DRILLING. ALSO, CALL "DIG-SAFE" AT (888)344-7233 (1(888)DIG-SAFE). EXISTING LINES OTHER THAN THOSE INDICATED ON THESE DRAWINGS MAY BE ON THE SITE. THE CONTRACTOR IS WARNED TO PROCEED WITH CAUTION WITH ALL WORK, ESPECIALLY EXCAVATION WORK, AND TO MAKE ALL POSSIBLE INVESTIGATIONS AS TO POSSIBLE UNMARKED UTILITY LINES.

- LEGEND**
- UTILITY POLE
 - DRAIN MANHOLE
 - CATCH BASIN
 - DRAIN LINE
 - FENCE
 - TREE LINE
 - SHRUB
 - SPOT ELEVATION
 - RIP-RAP
 - MANHOLE
 - PARKING SPACES
 - SILT FENCE
 - MULCH SOCK

OWNER:
GOLD MEDALIST LLC
25 CAPE ROAD,
MENDON, MA.

APPLICANT:
ABRAHAM JREIJ
234 WEST STREET
MILFORD, MA 01757
508-473-5800

21 CAPE ROAD

"EROSION CONTROL"
AMENDED SITE
PLAN OF LAND
IN
MENDON, MA
SCALE: 20 FEET TO AN INCH
DATE: JUNE 18, 2020

REV.	DATE	COMMENT

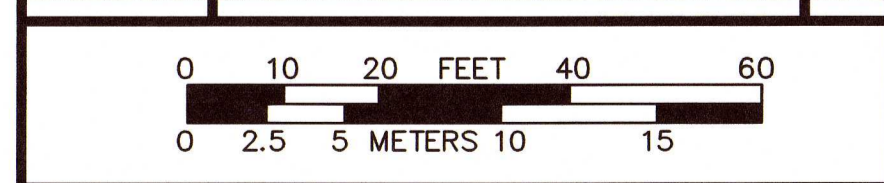

The Meehan Group
P.O. BOX 444, MENDON, MA 01756 •
PHONE 508-473-2900 • FAX 508-634-5456